

Bâti-support WC
VERSO 350

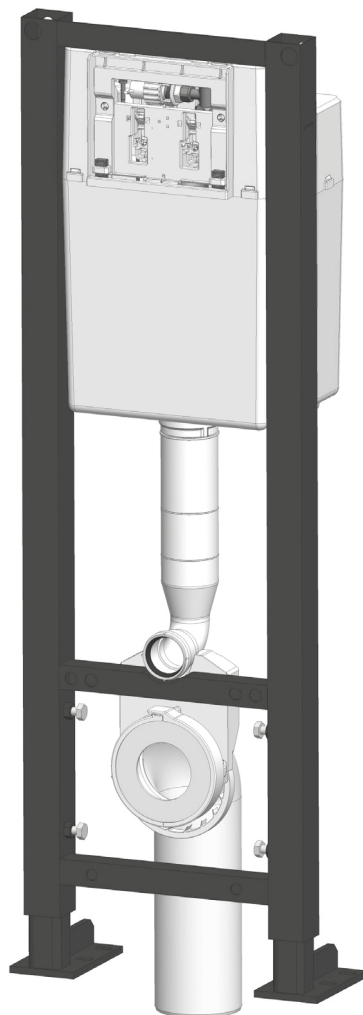

SIAMP

Monaco



ÉCLATÉ

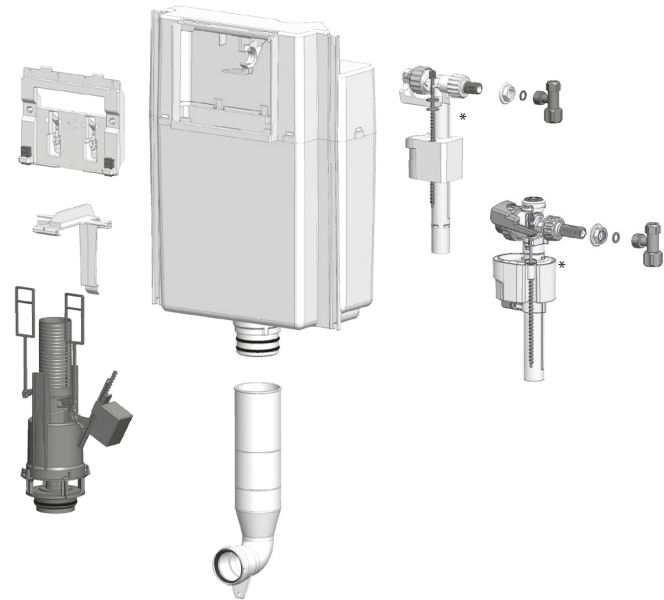
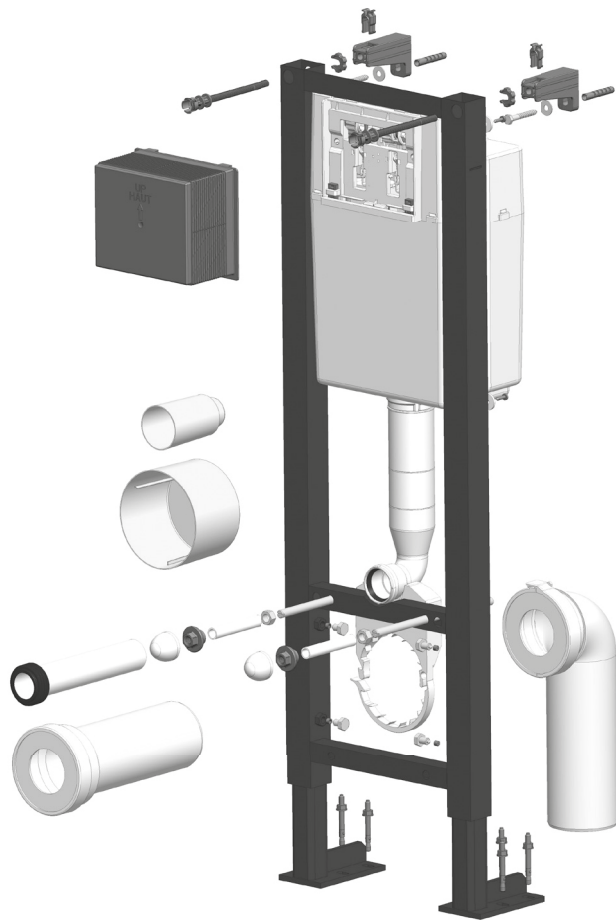

*Selon version

PAROIS

ARRIÈRE

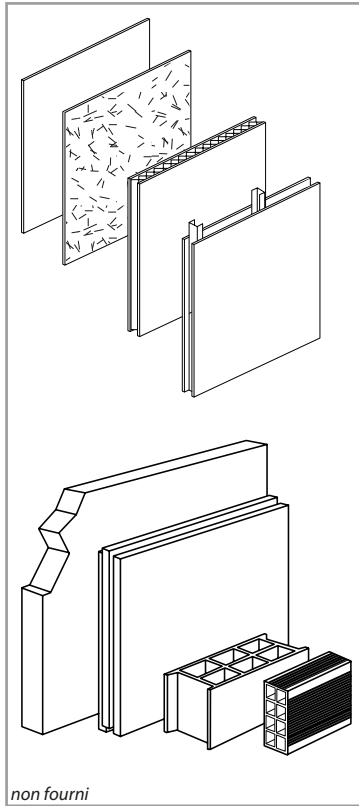

AVANT

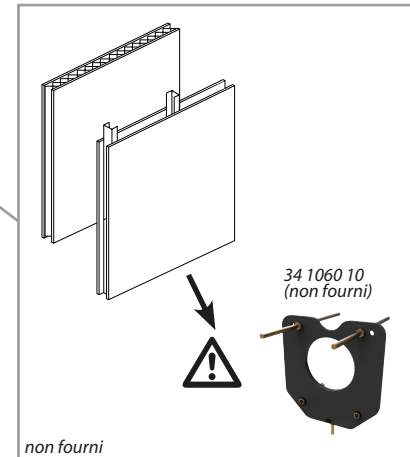
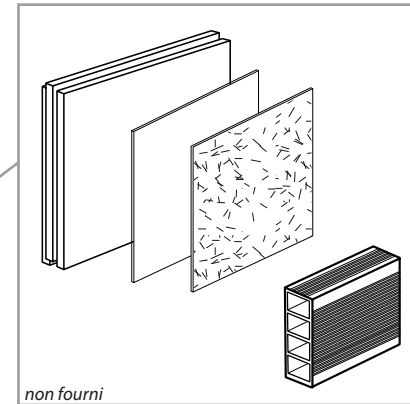

CAS DE POSE

Cas A

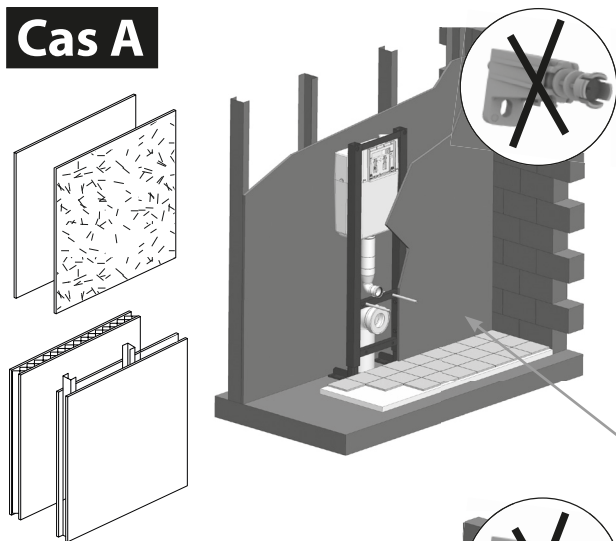

Cas C

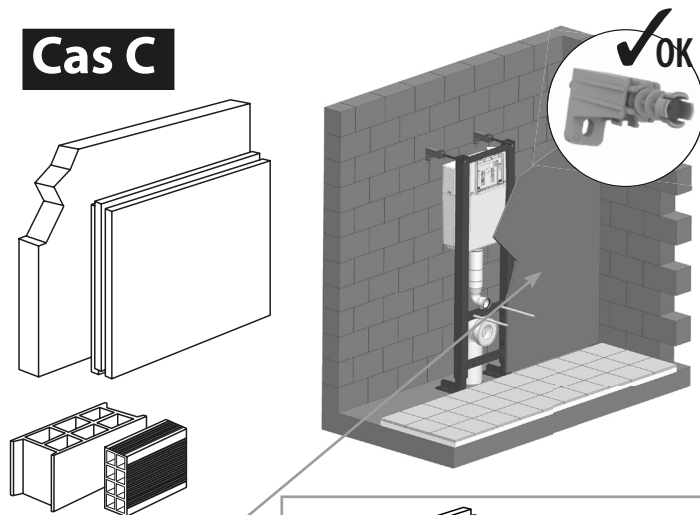

Cas B

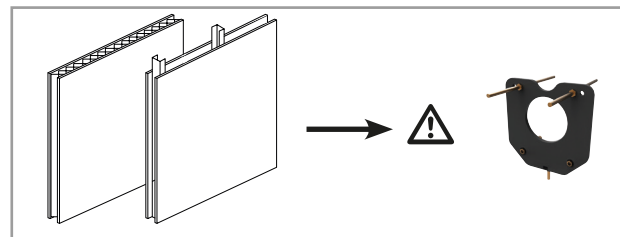
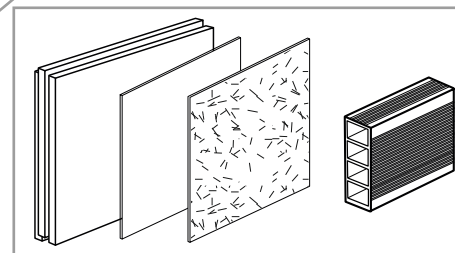
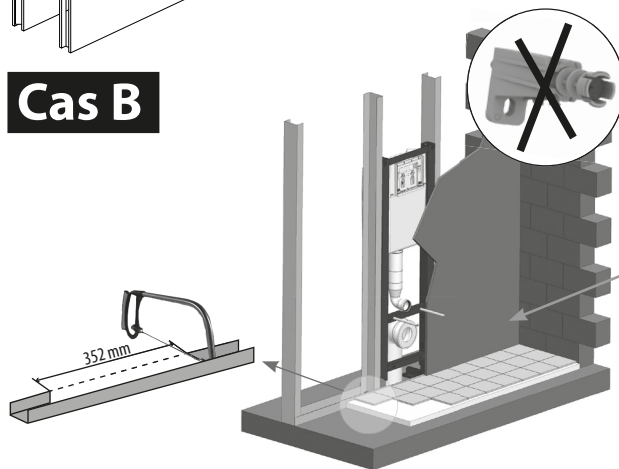

PRISE DE CÔTE

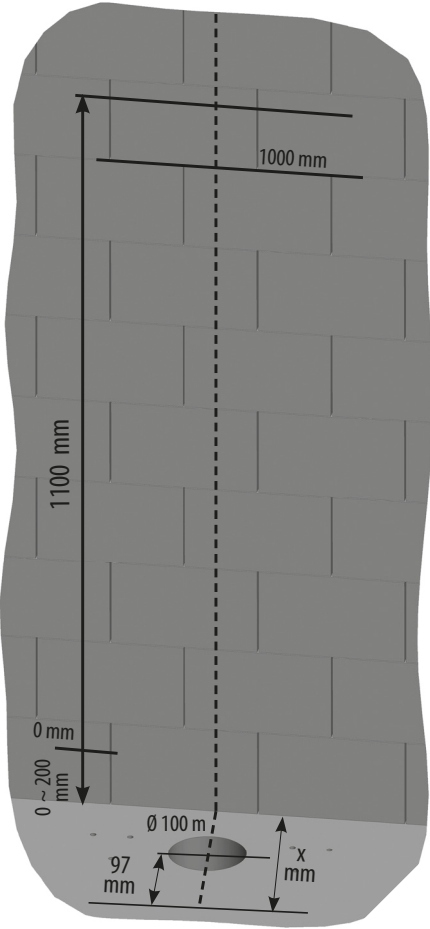

Vue de dessus

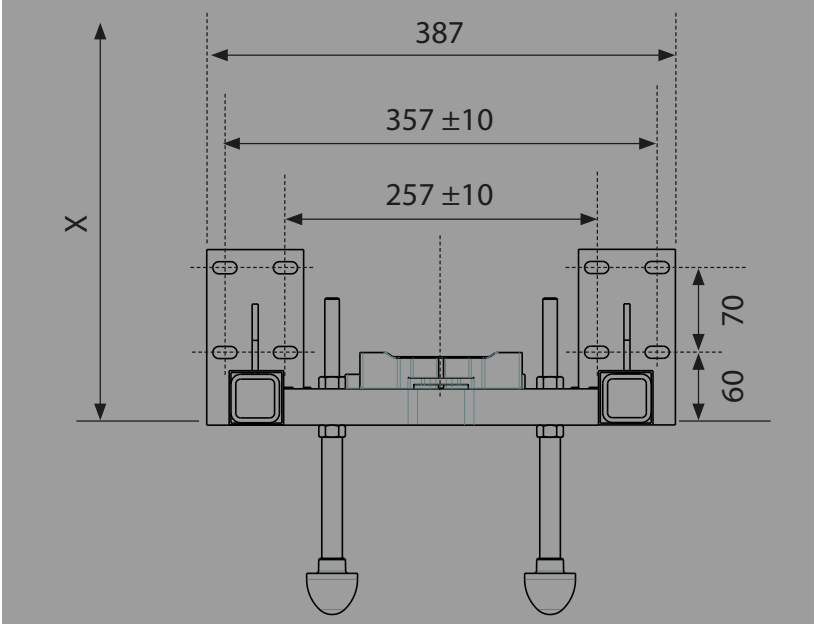

RÉGLAGE EN HAUTEUR

1

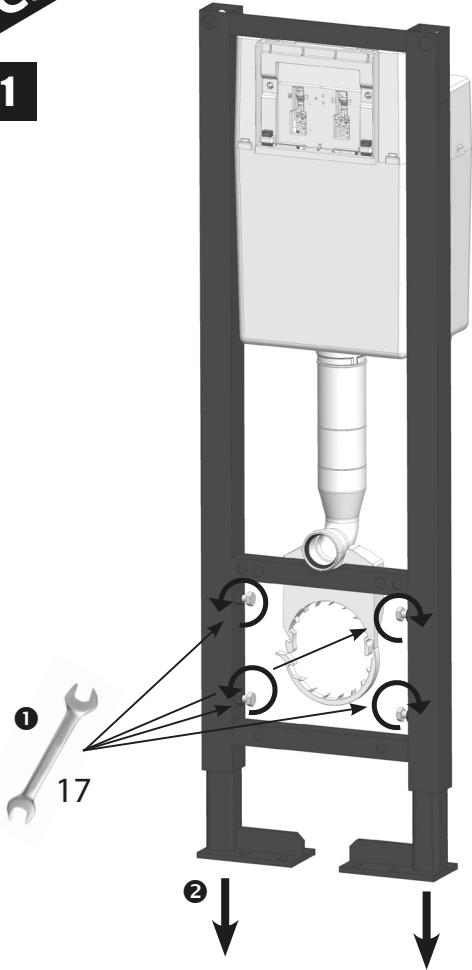

2

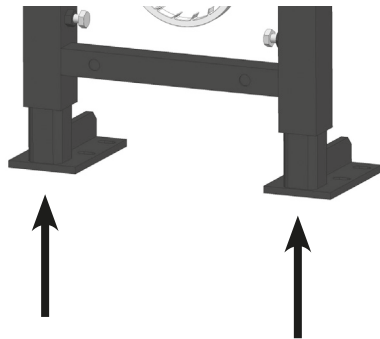

3

Visser à la main jusqu'à ce que les vis opposent une résistance

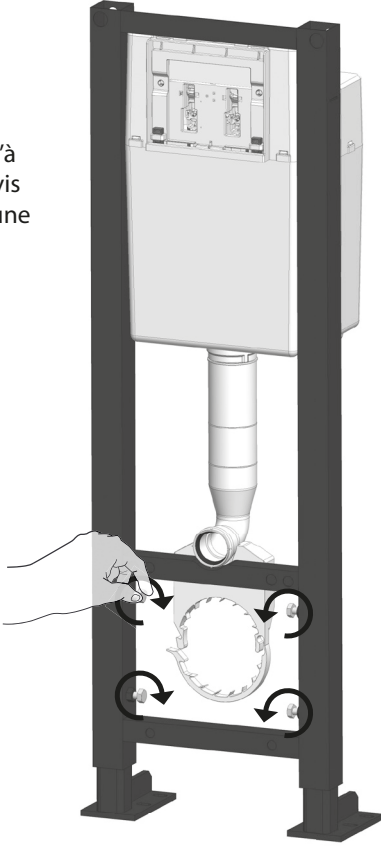

4

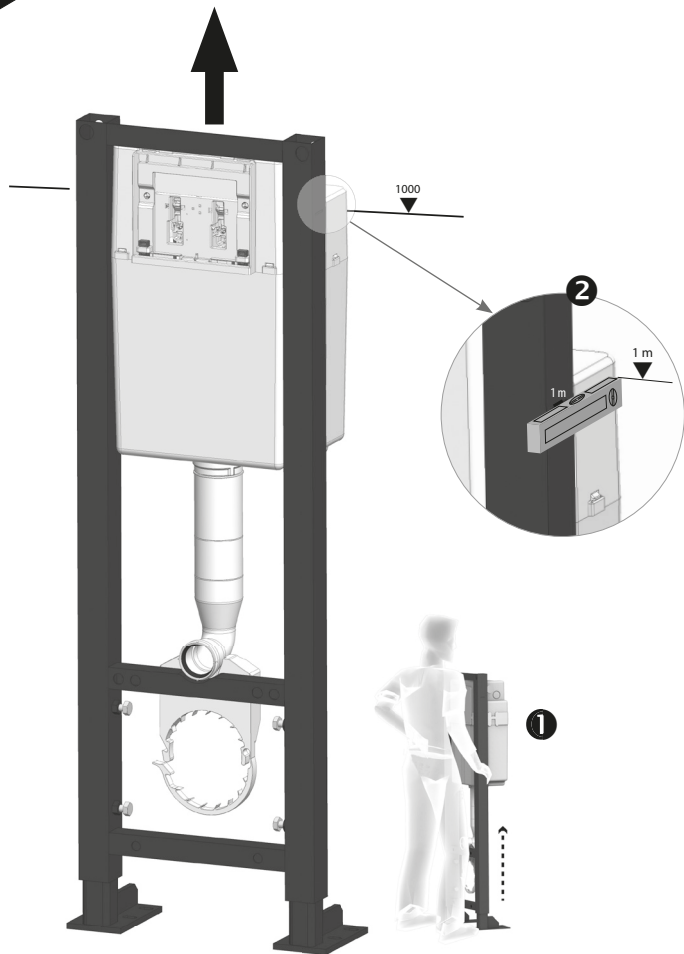

5

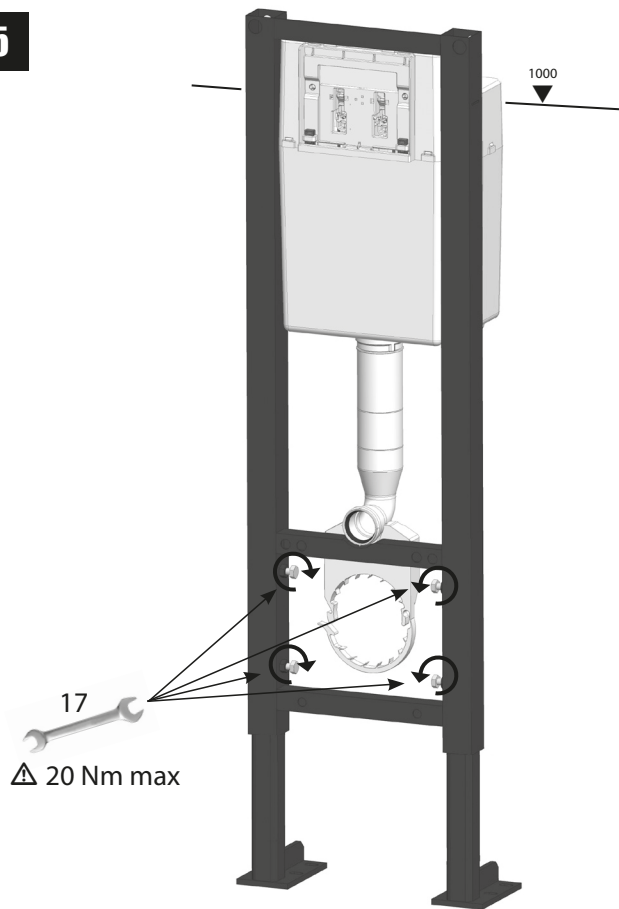

TRAÇAGE & PERÇAGE

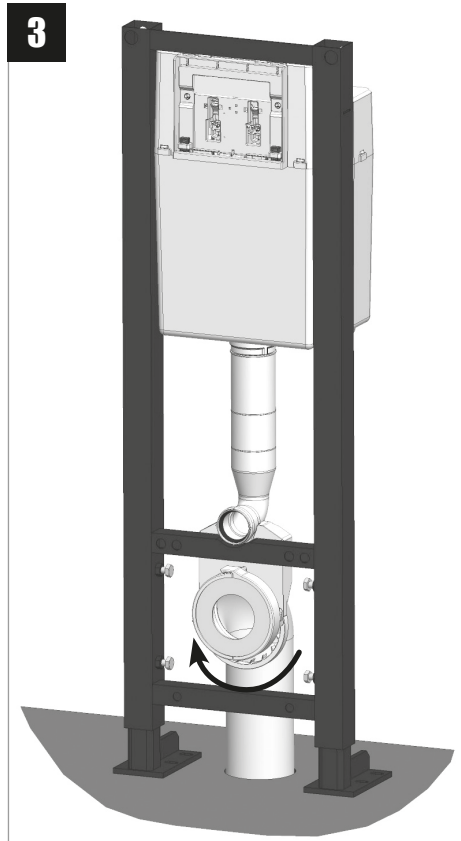
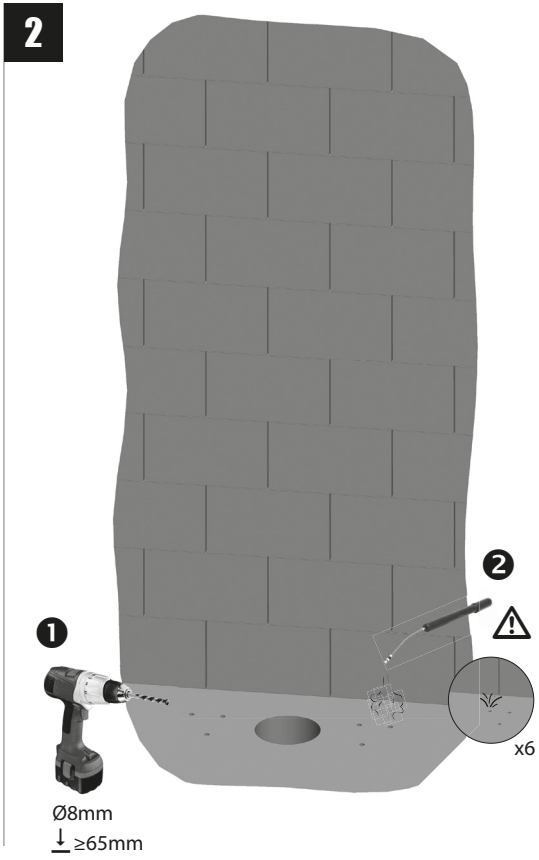
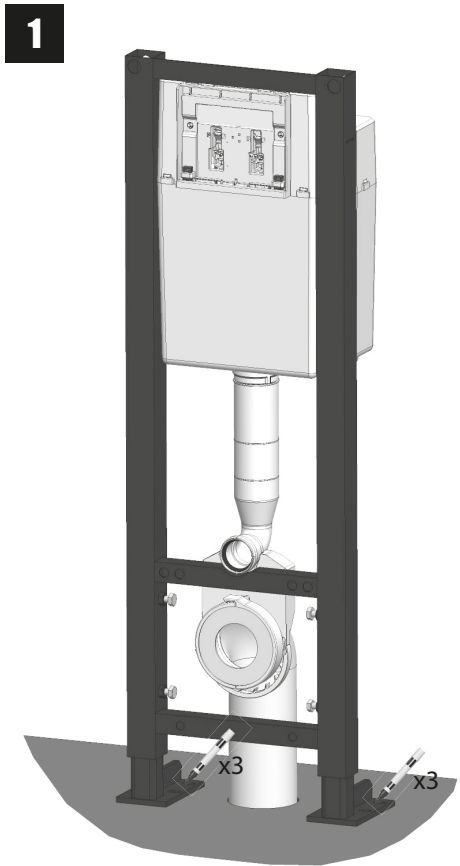

FIXATION

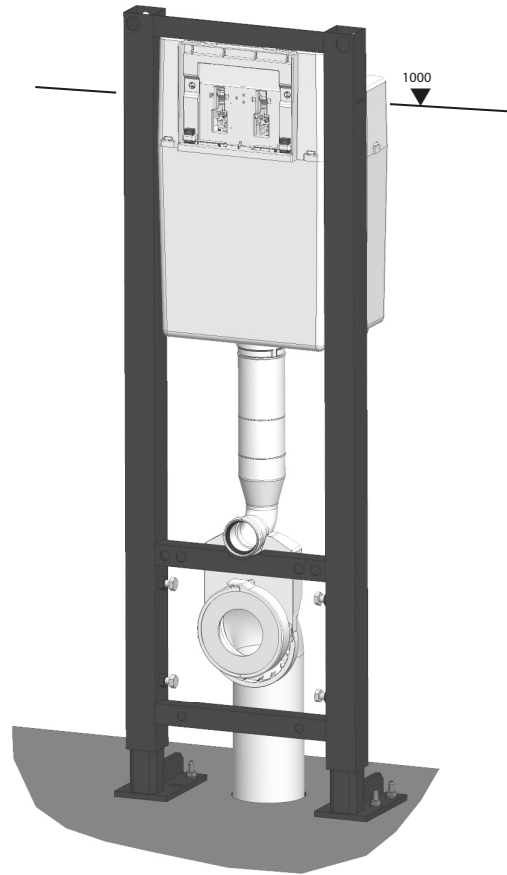
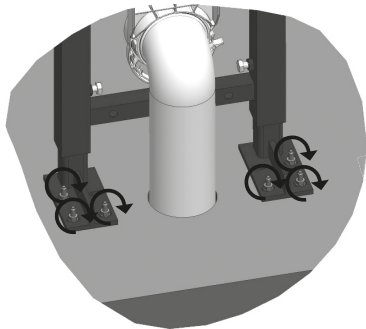
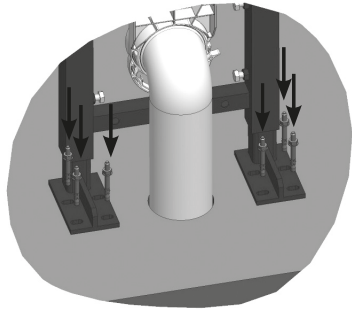

CONNEXION EN EAU



Pour les réservoirs de chasse équipés de Quieto OD uniquement :

Pression < 1 bar

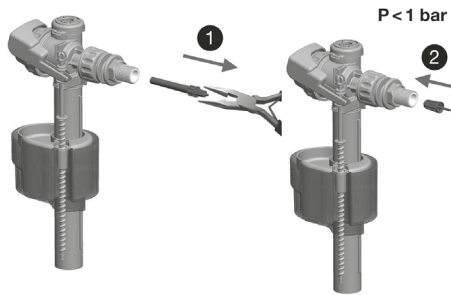

1

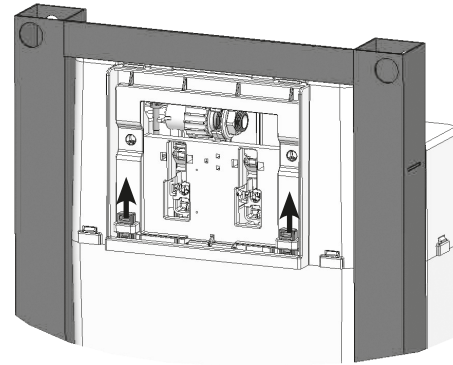

2

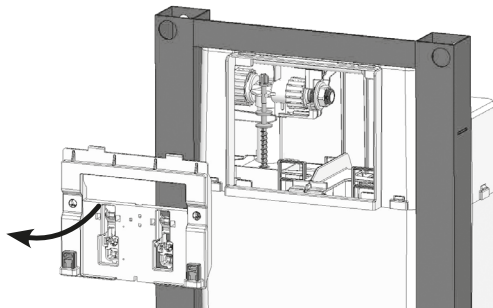

3

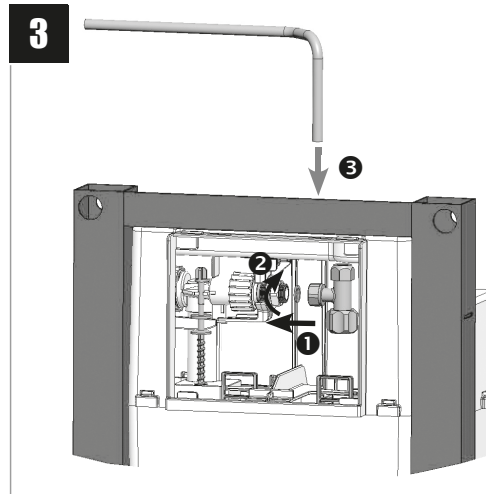

4

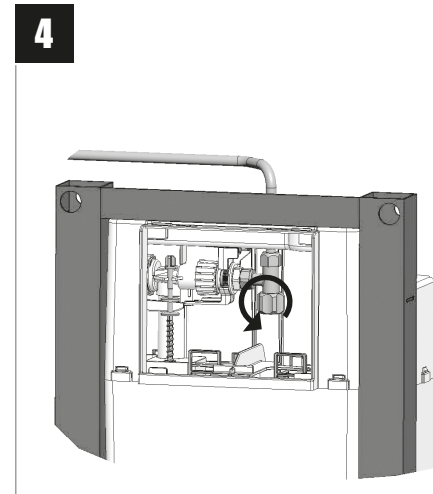

PRÉPARATION DE L'HABILLAGE

1

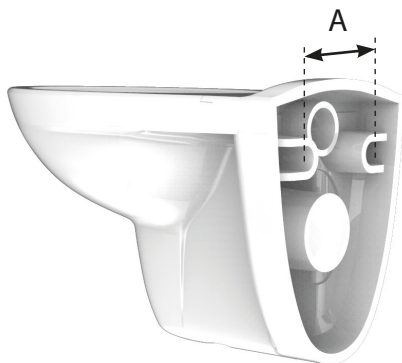

A = 180 mm → **2a**

A = 230 mm → **2b**

2a

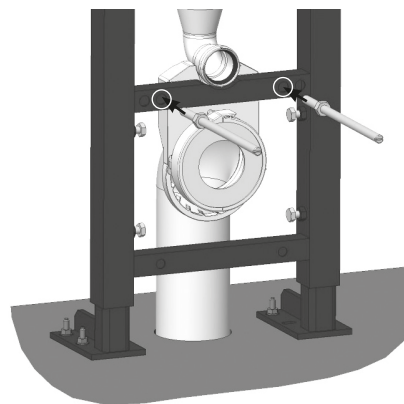

2b

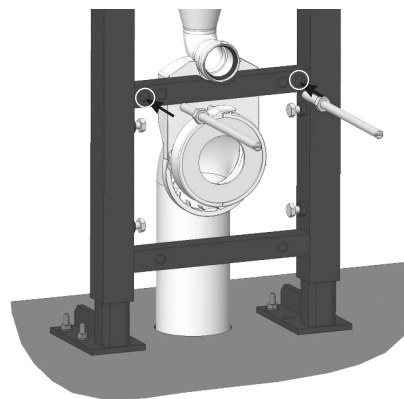

PRÉPARATION DE L'HABILLAGE

1

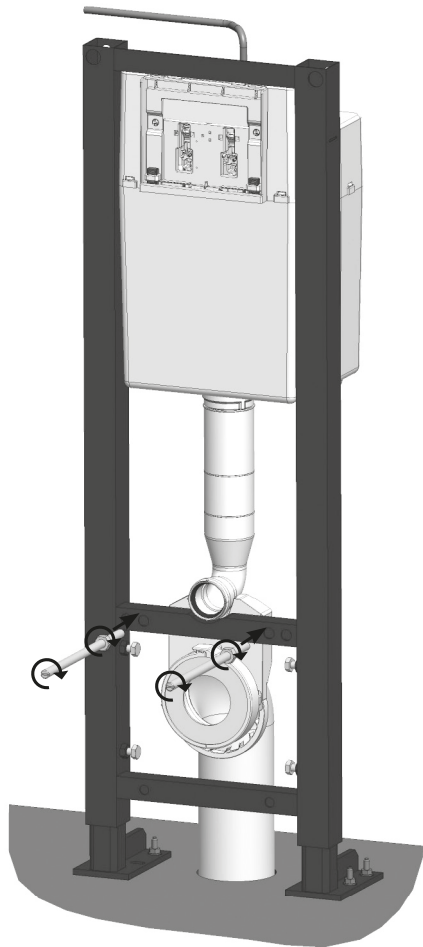

2

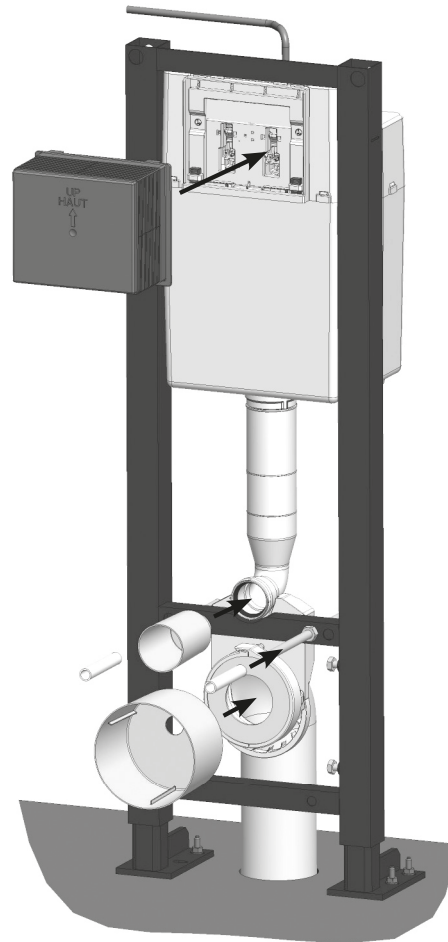

PRÉPARATION DE L'HABILLAGE

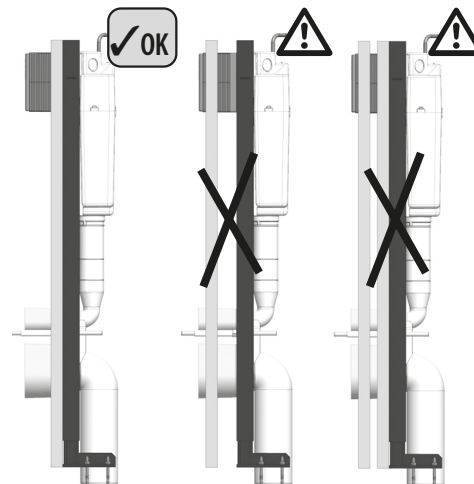
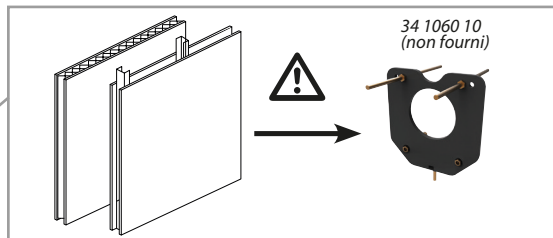
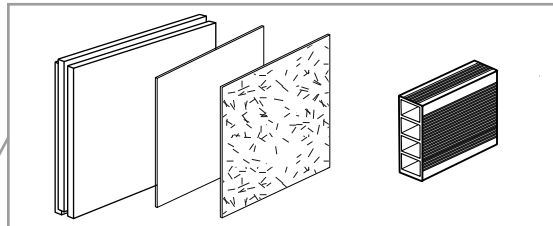
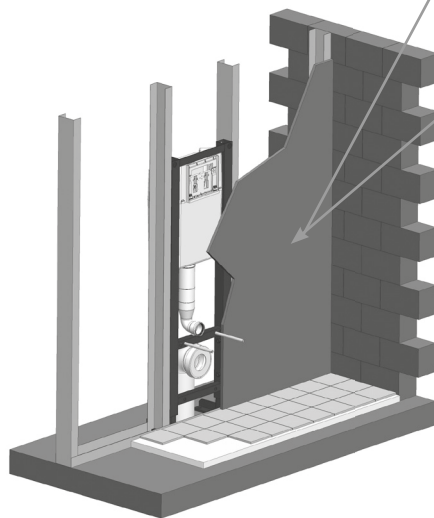
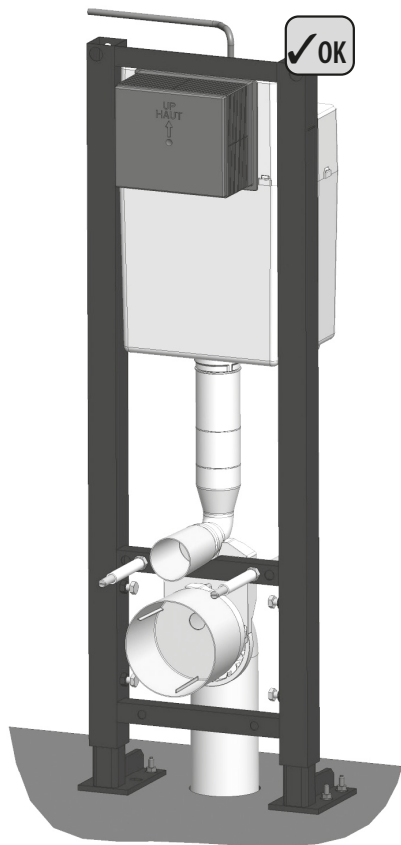

Cas C

PRISE DE CÔTE (Liaison murale haute optionnelle)

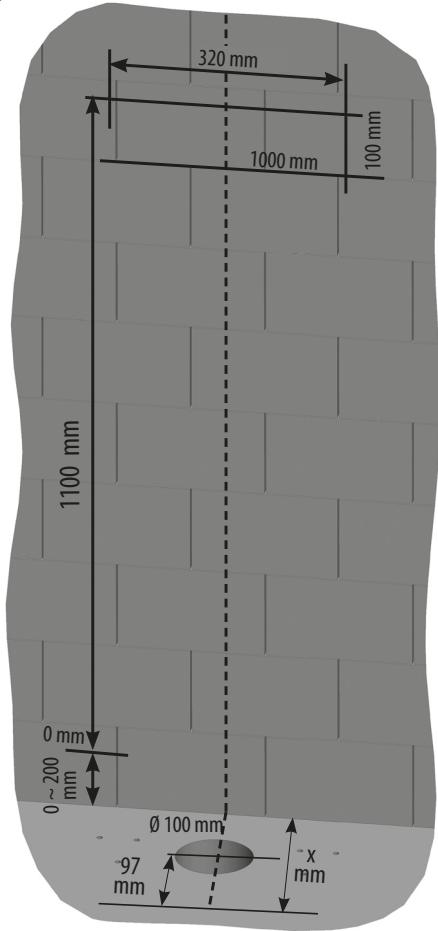

Vue de dessus

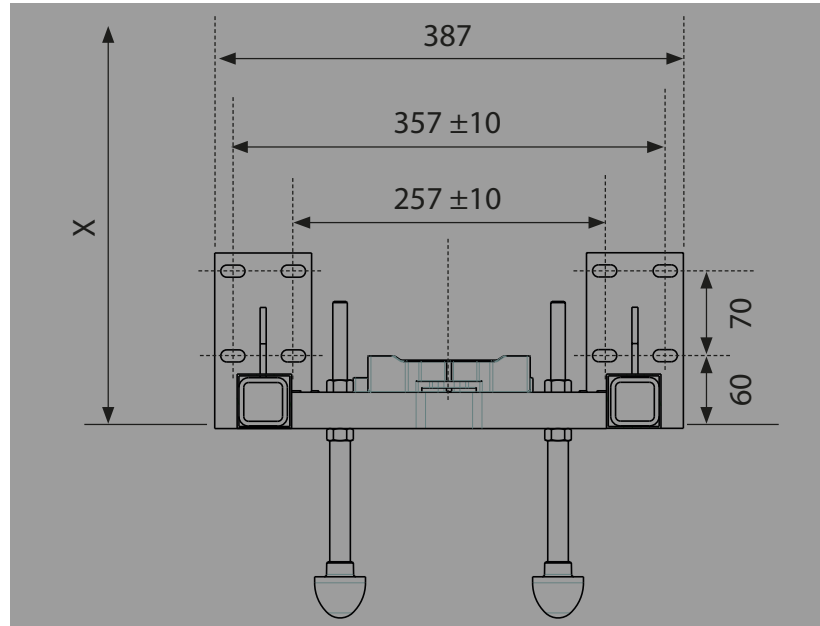

INSTALLATION FIXATION HAUTE (Liaison murale haute optionnelle)

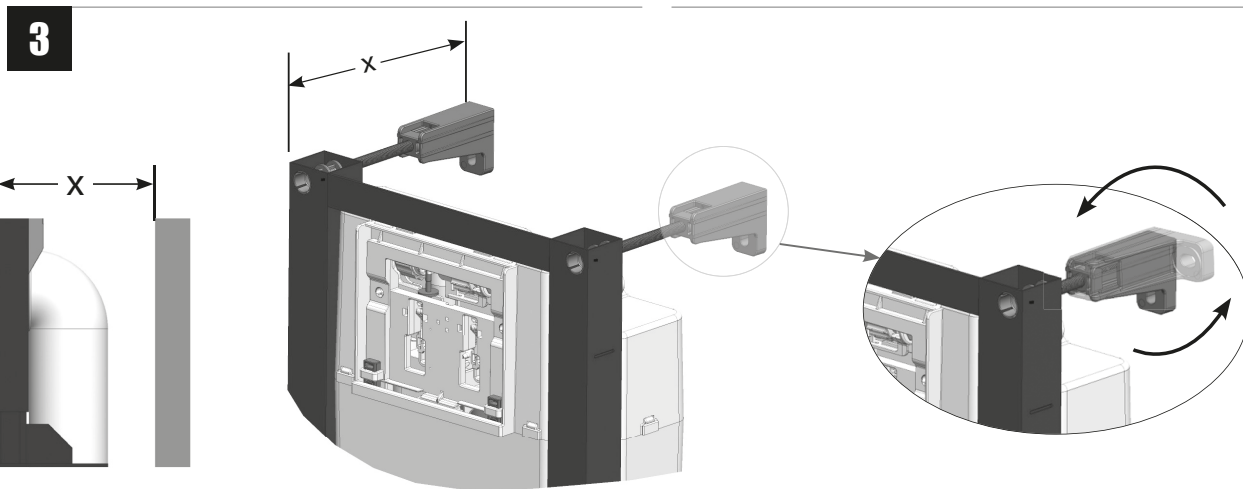
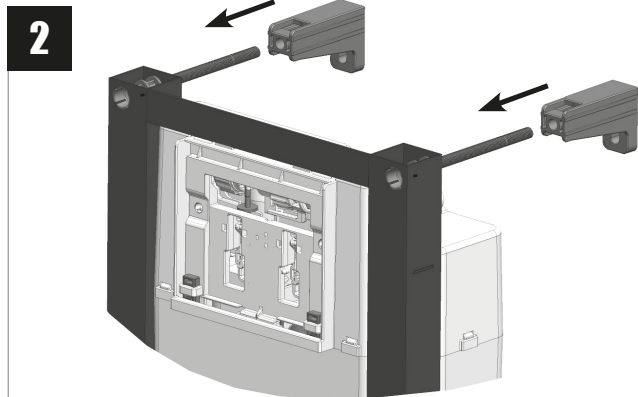
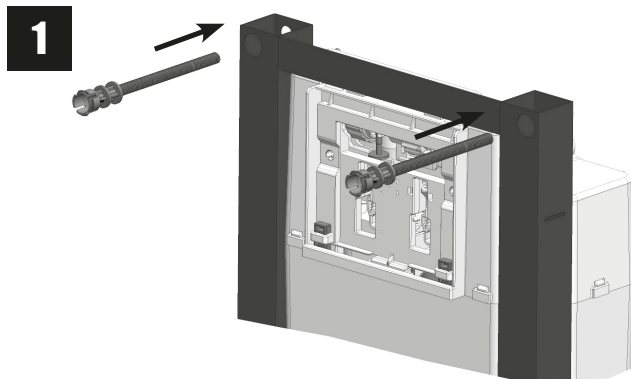

Cas C

INSTALLATION FIXATION HAUTE (Liaison murale haute optionnelle)

si $x \leq 180$ mm

4

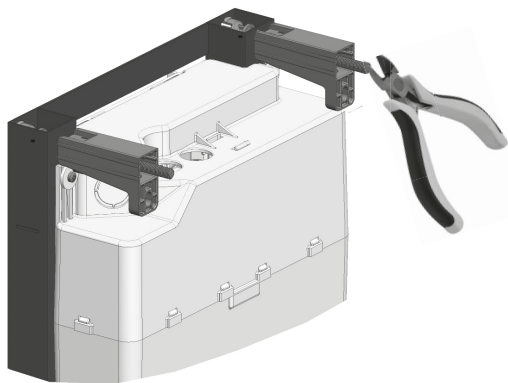

5

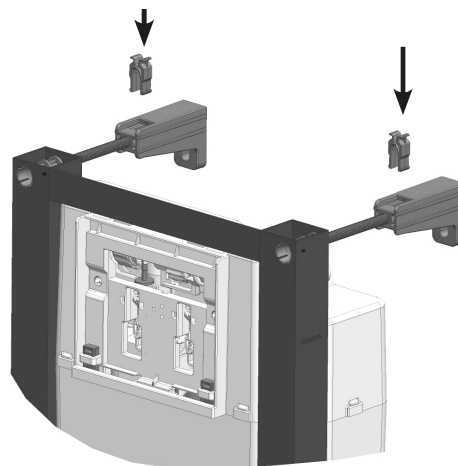

6

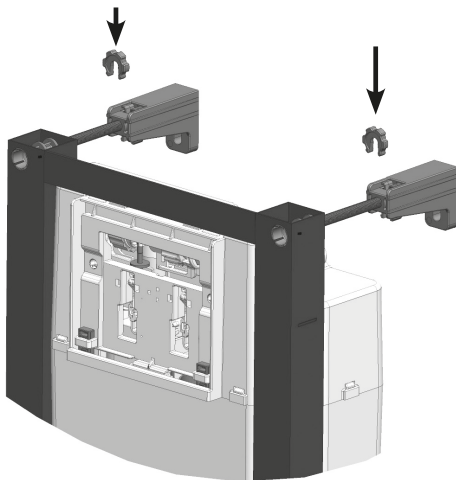

7

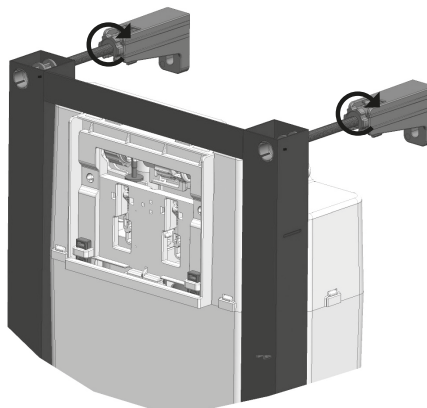

RÉGLAGE EN HAUTEUR (Liaison murale haute optionnelle)

1

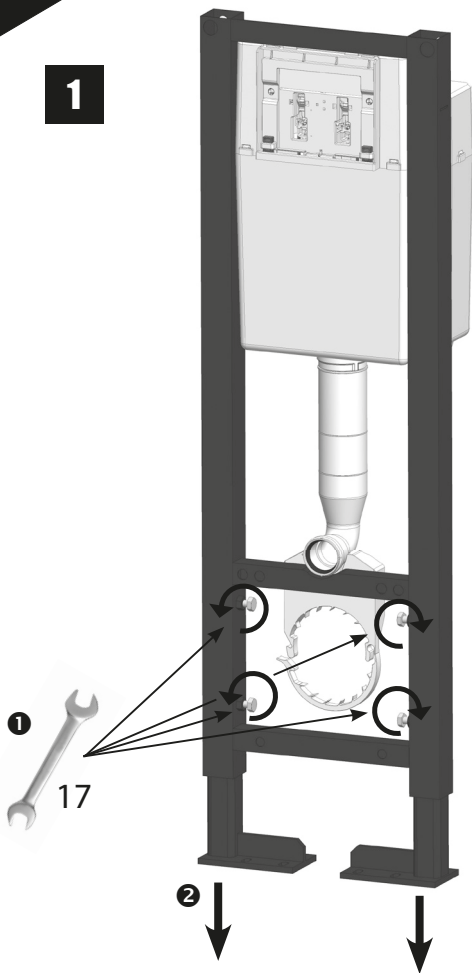

2

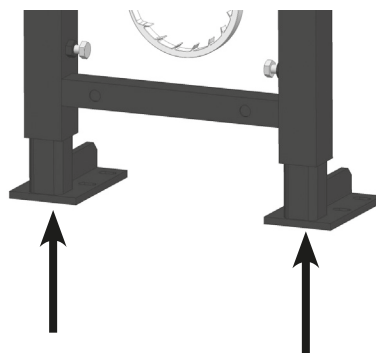

3

Visser à la main jusqu'à ce que les vis opposent une résistance

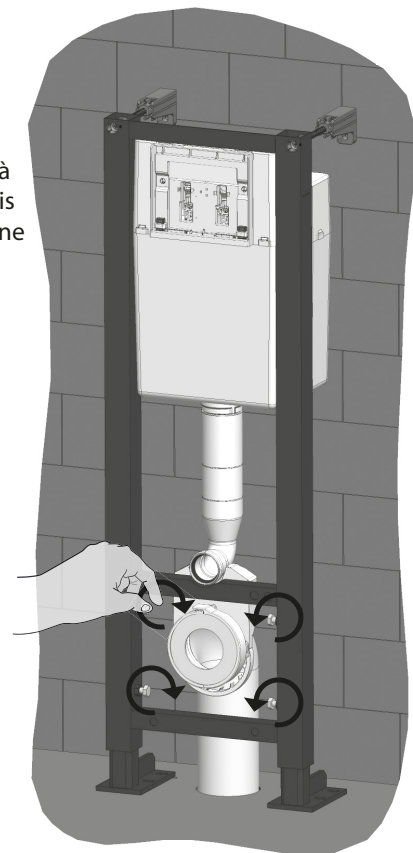

Cas C

RÉGLAGE EN HAUTEUR (Liaison murale haute optionnelle)

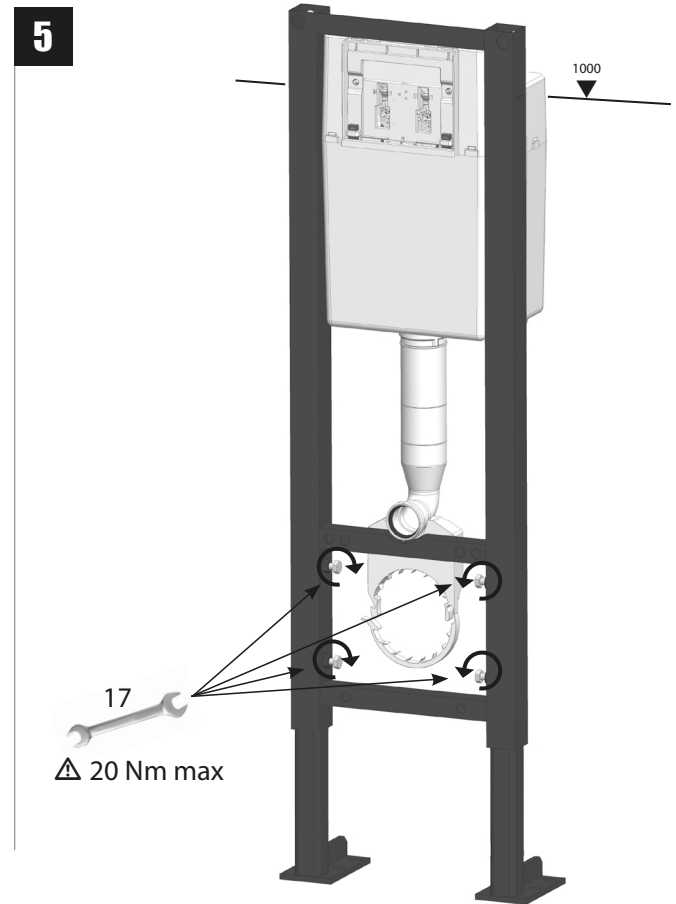
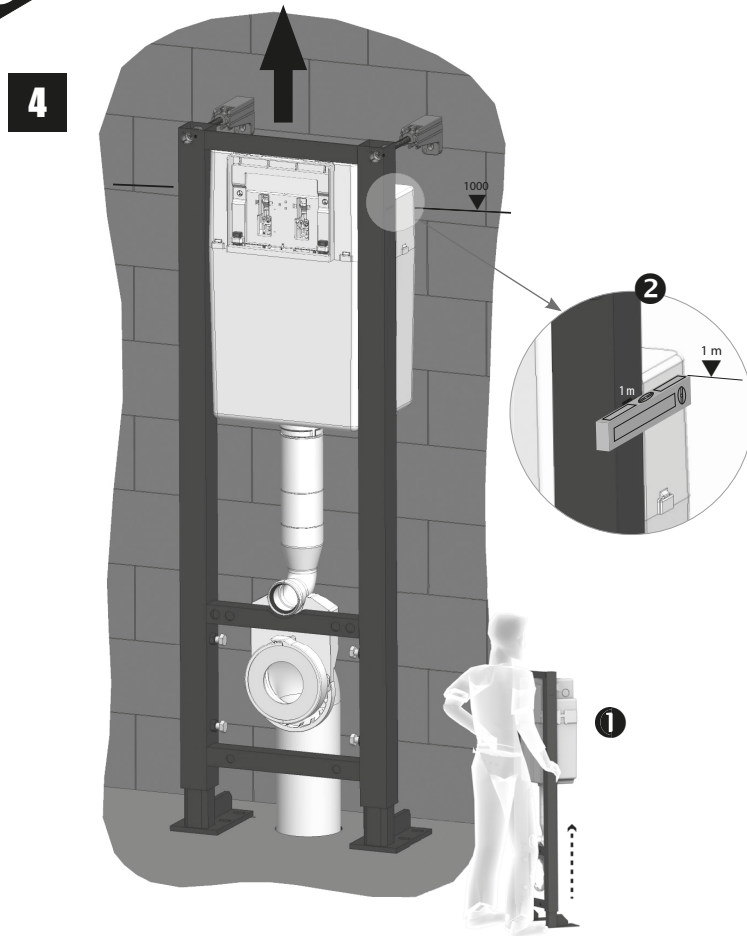

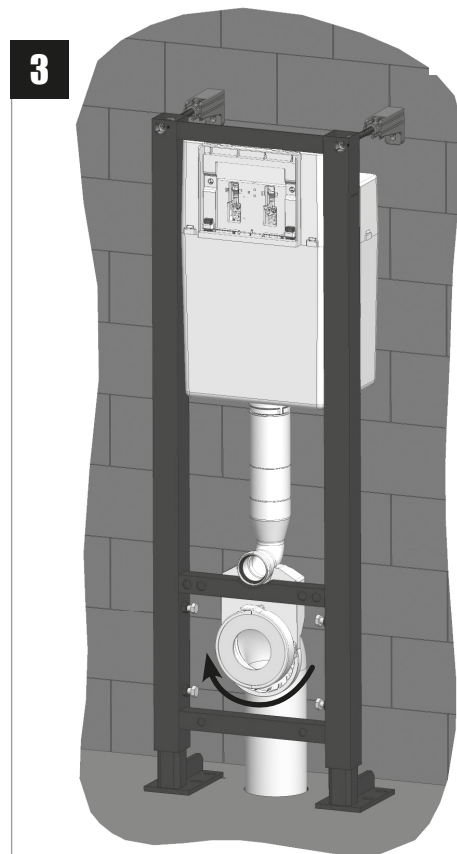
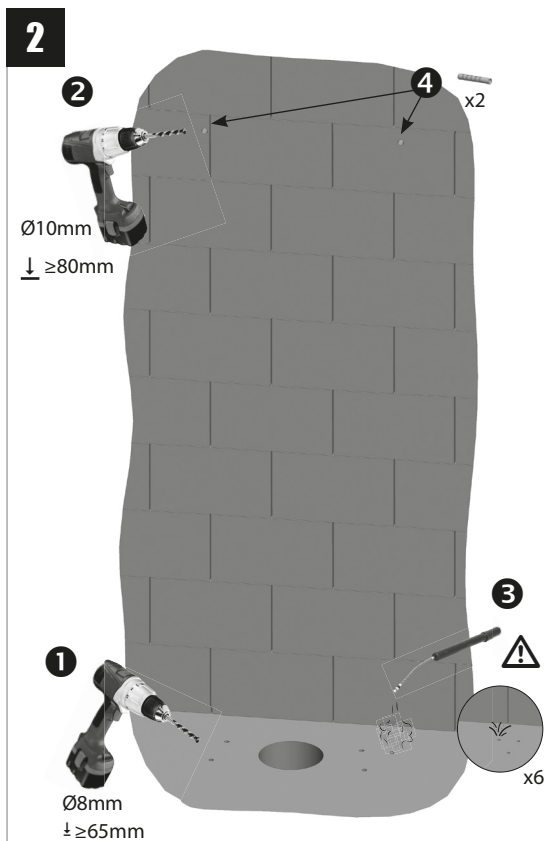
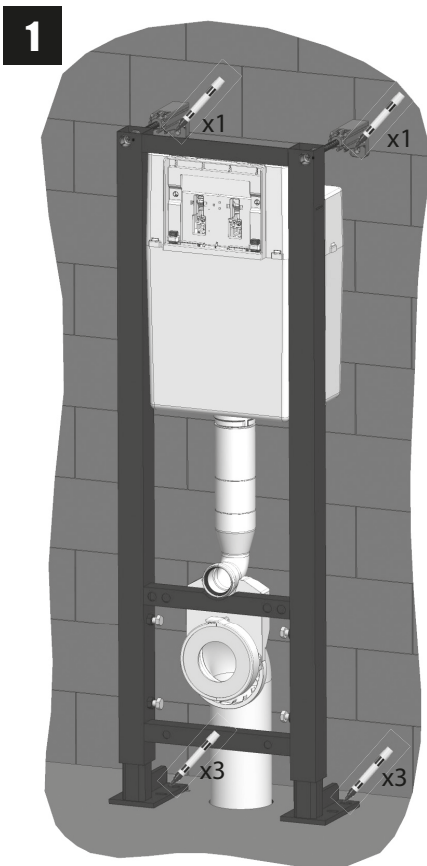

Cas C

FIXATION (Liaison murale haute optionnelle)

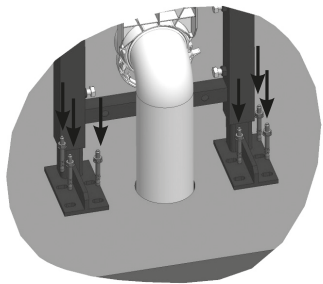

1
x6

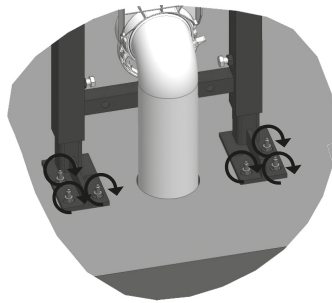

2
13
x6

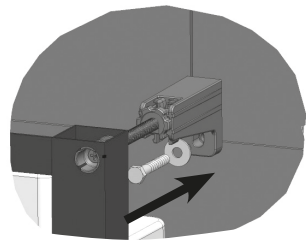

3
13
x2

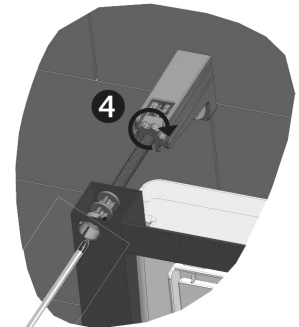
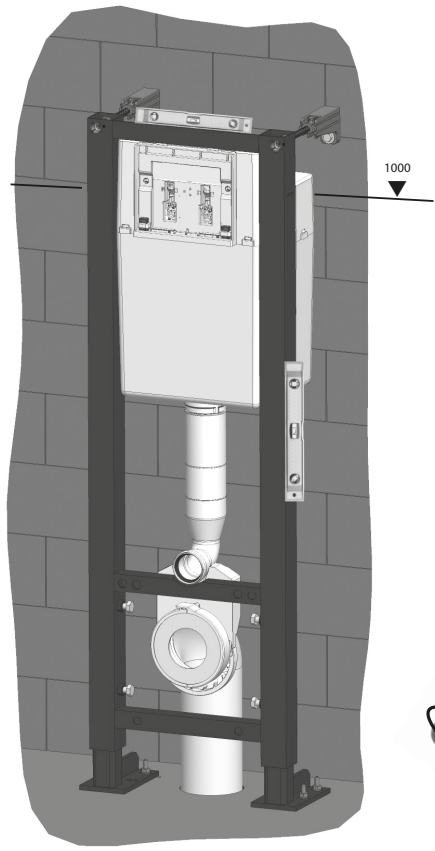

5



➔ P. 12







10 0020 33

SIAMP

Monaco

4, quai Antoine 1er - BP 219 - MC 98007 MONACO Cedex
Fax : +377 92 05 71 04 - contact@siamp.com - www.siamp.fr



VERSO 350

SIAMP

Monaco

Installation PLAQUE DE COMMANDE



INSTALLATION PLAQUE DE COMMANDE

1

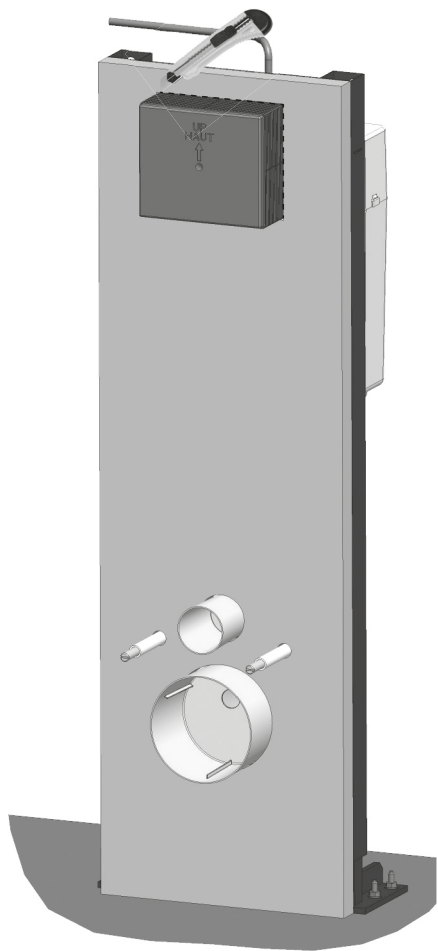

2

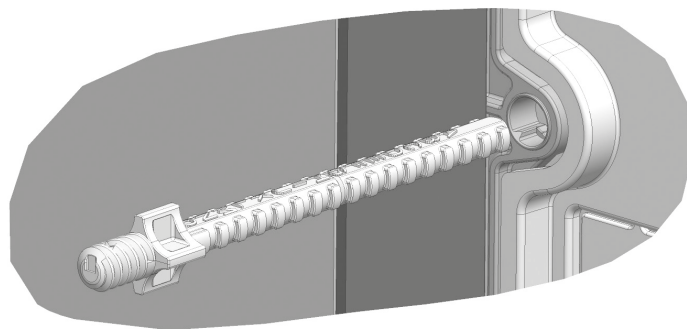
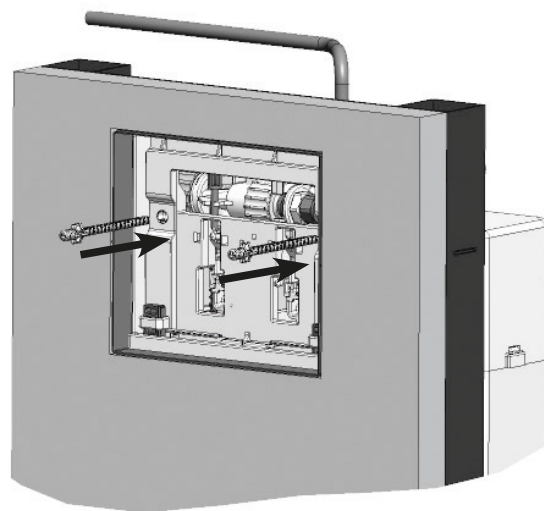

INSTALLATION PLAQUE DE COMMANDE

3

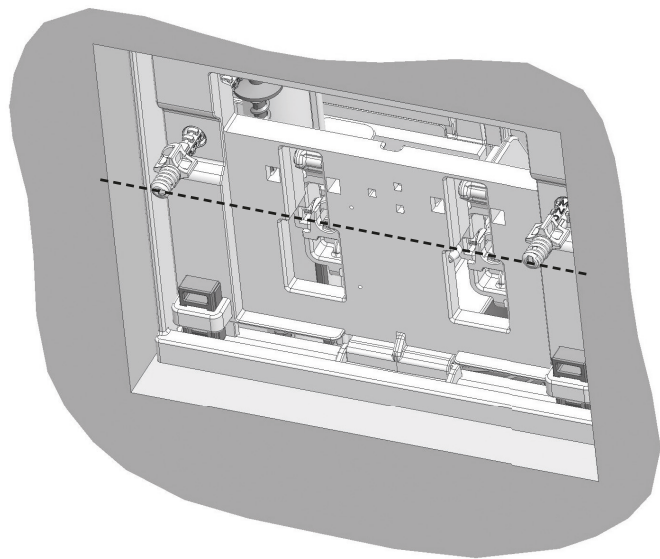

4

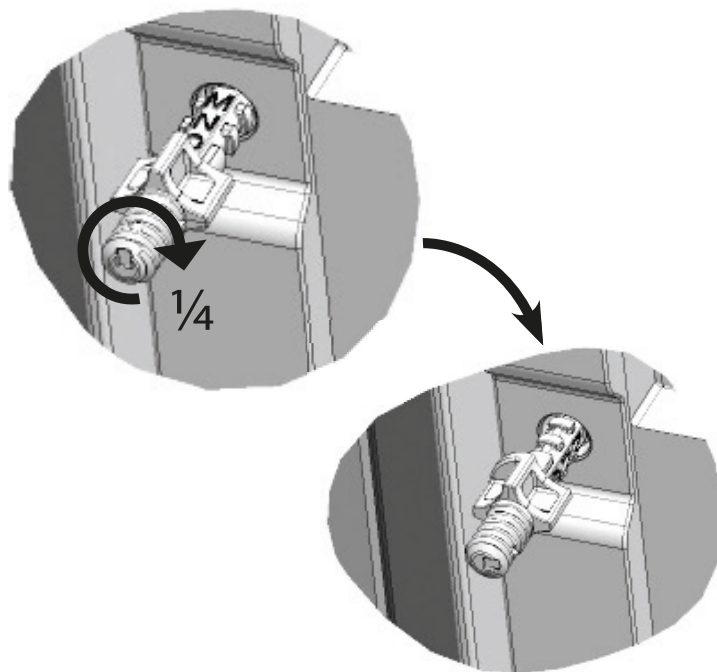

INSTALLATION PLAQUE DE COMMANDE

5

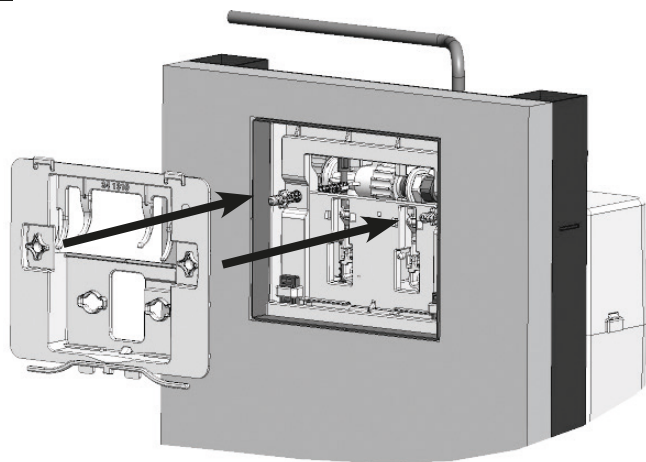

6

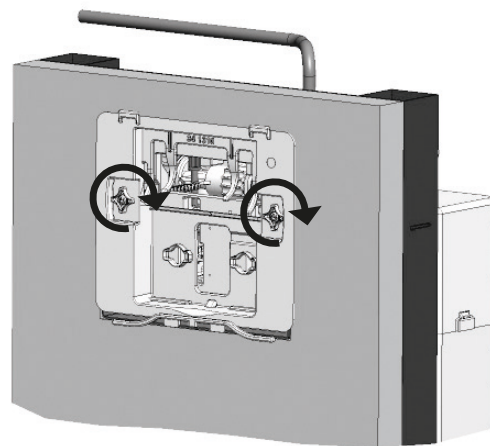

INSTALLATION PLAQUE DE COMMANDE

7

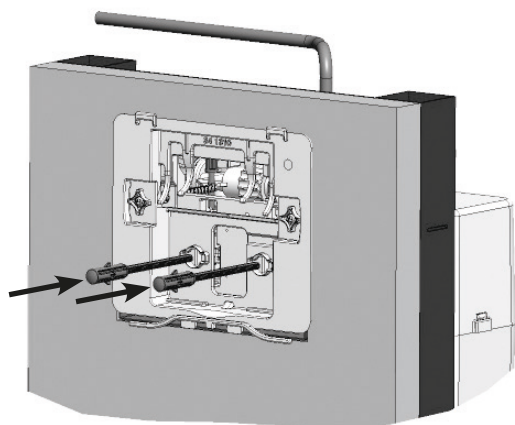

8

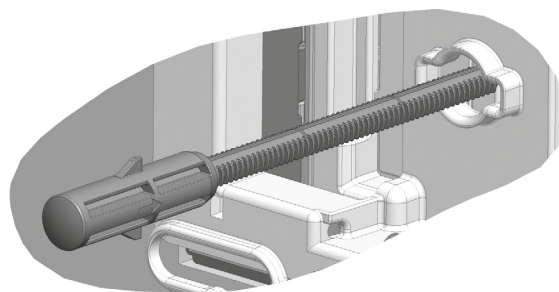

INSTALLATION PLAQUE DE COMMANDE

9

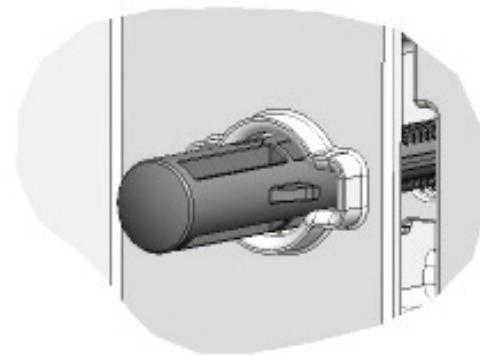
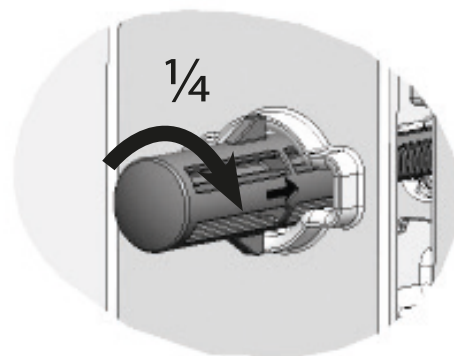
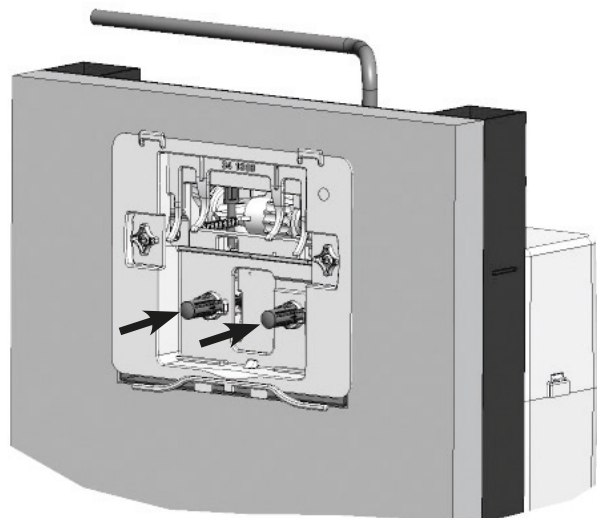

INSTALLATION PLAQUE DE COMMANDE

10

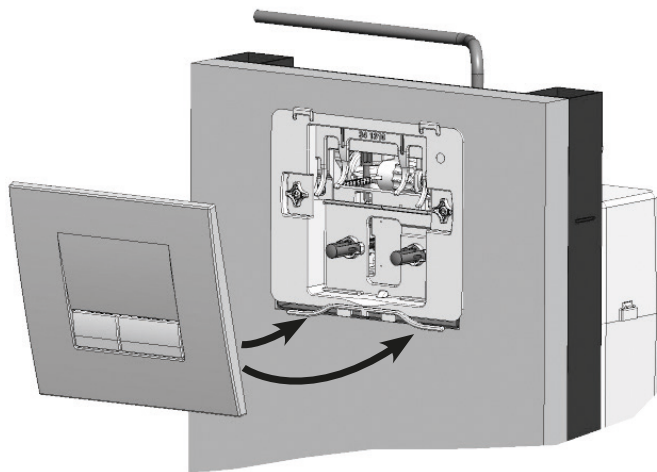

11

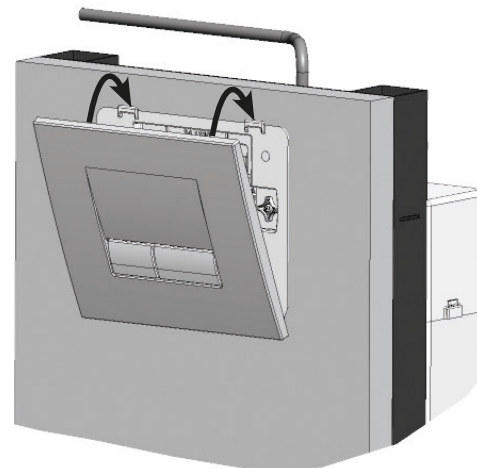

Monaco

SIAMP

4, quai Antoine 1er - BP 219 - MC 98007 MONACO Cedex
Fax : +377 92 05 71 04 - contact@siamp.com - www.siamp.fr



10 0020 35

VERSO 350

SIAMP

Monaco

Installation CUVETTE



PRÉPARATION

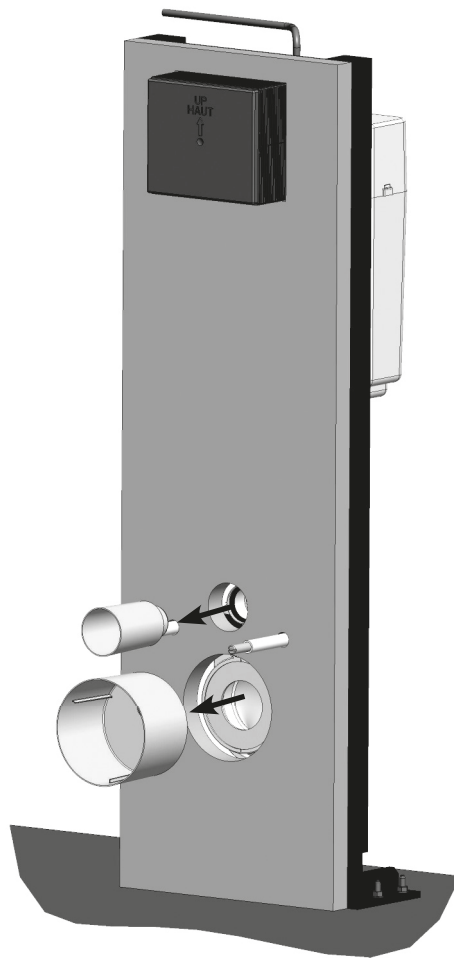

PRISE DE CÔTE

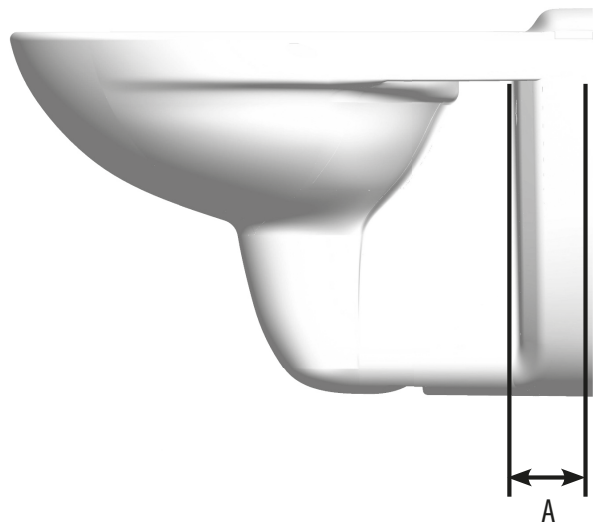

A+20 mm

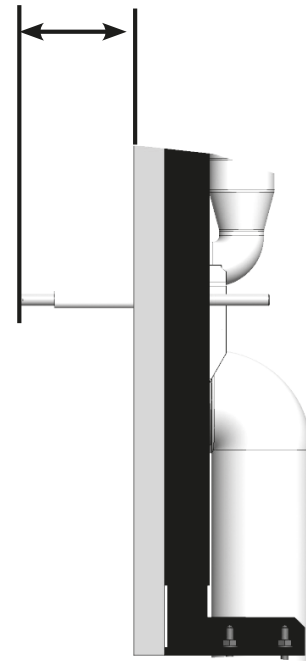

RÉGLAGE TIGES FILETÉES

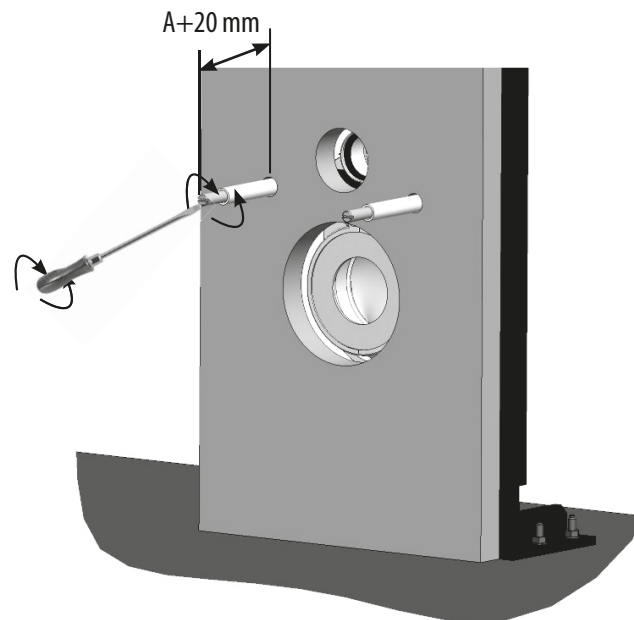

DÉCOUPE MANCHONS

1

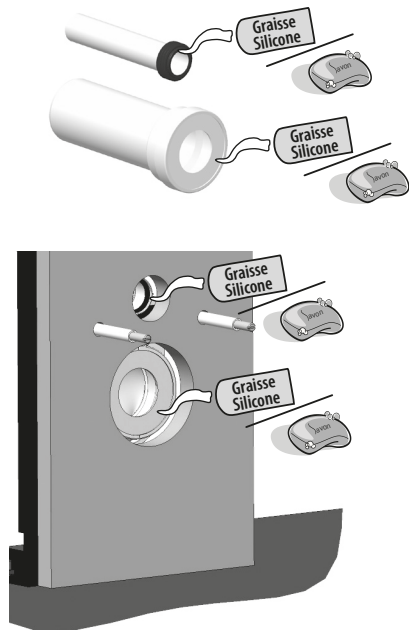

2

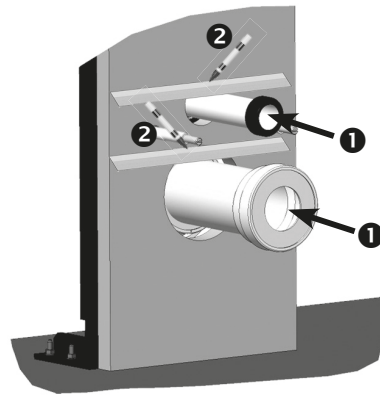

3

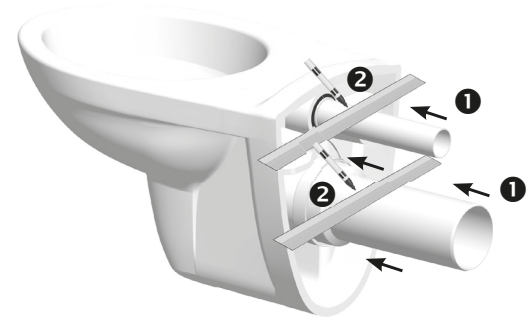

DÉCOUPE MANCHONS

4

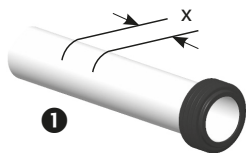

1

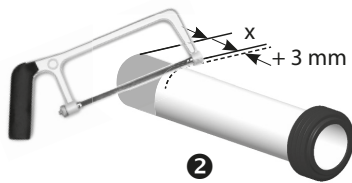

2

5

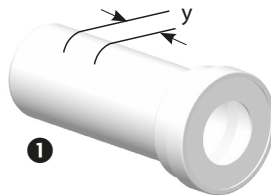

1

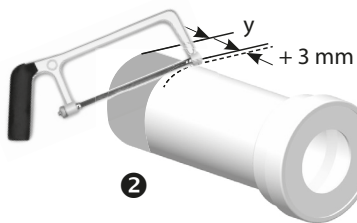

2

6

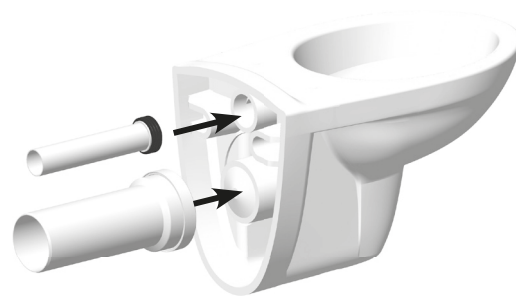

FIXATION

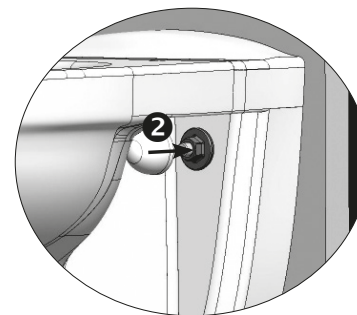
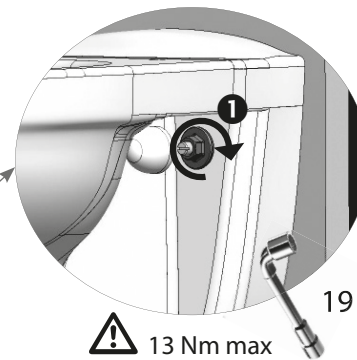



10 0020 36

SIAMP
Monaco

4, quai Antoine 1er - BP 219 - MC 98007 MONACO Cedex
Fax : +377 92 05 71 04 - contact@siamp.com - www.siamp.fr

NOTICE D'INSTALLATION ABATTANT AVEC FERMETURE RALENTIE ET DÉCLIPSABLE, FIXATION PAR LE DESSOUS

