

A700P - Remorque pedestre

MOTTEZ

Conception et fabrication française

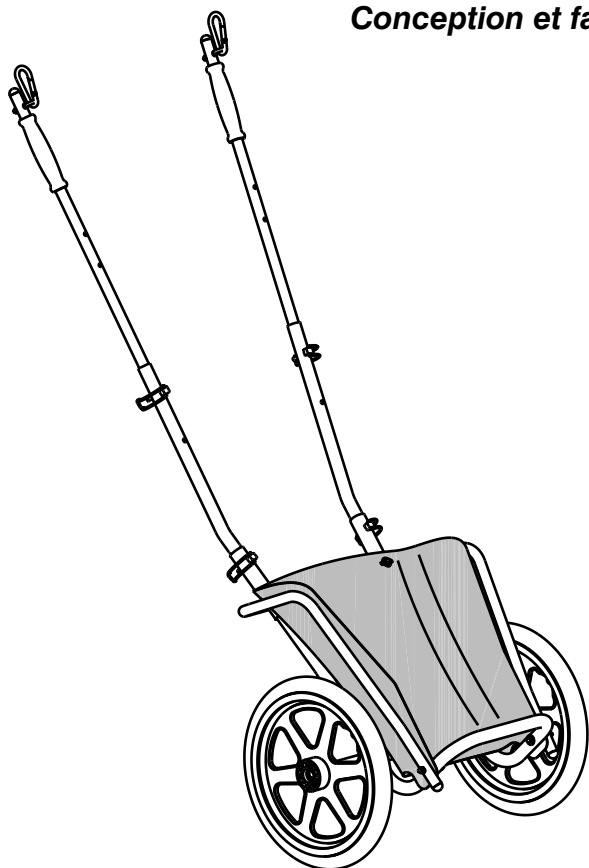

Produit breveté et modèle déposé

Poids à vide du produit : 6 KG

Charge maxi supportée : 30 kg

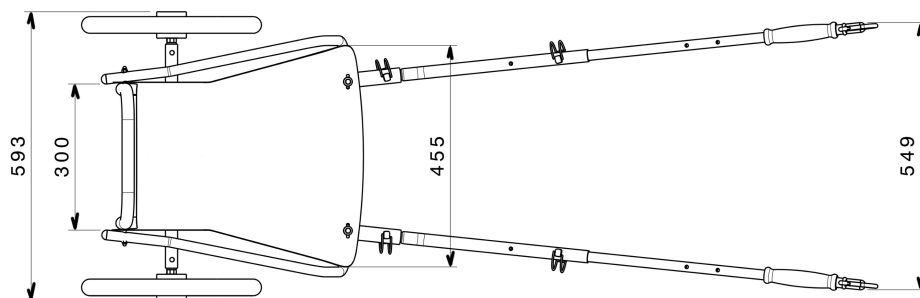
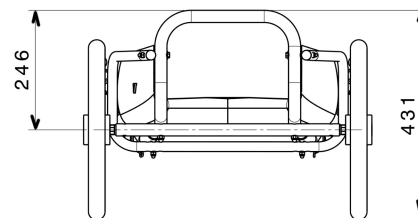
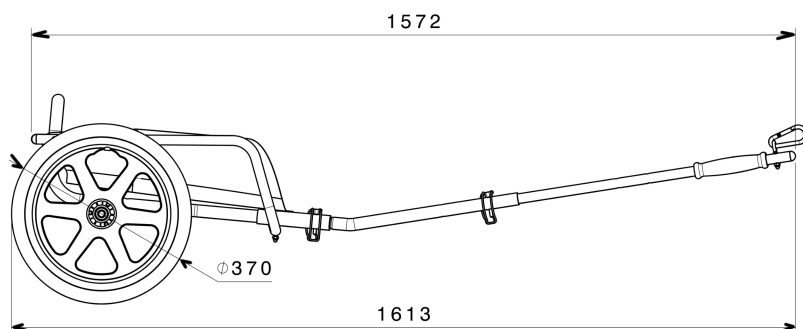

SAV

MOTTEZ

Si malgré toutes les précautions prises lors de la conception du produit, vous deviez rencontrer un problème, notre Service Après Vente reste à votre disposition. Du lundi au jeudi : de 8h00 à 17h00 et le vendredi de 8h00 à 15h00



33 (0)3 20 10 90 25



be-sav@mottez.com



33 (0)3 20 10 37 89











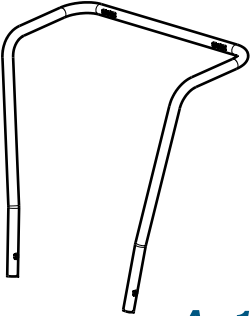
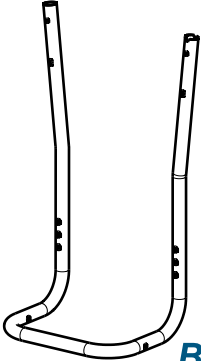
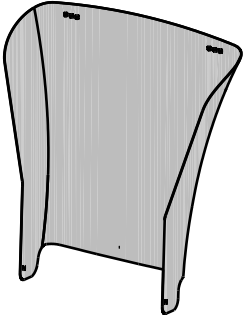

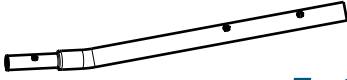
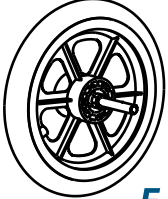
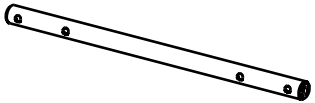
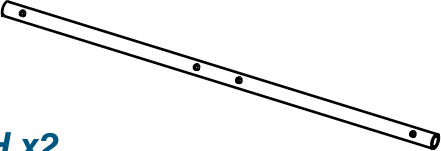

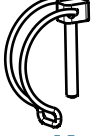

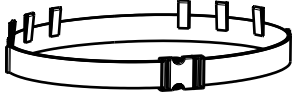
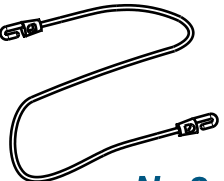

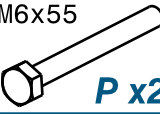
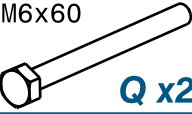
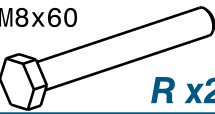
<http://www.chariotderandonnee.com>

CONA700P 19038

Lire impérativement la notice avant toute utilisation

Composants

 A x1	 B x1	 C x1	 D x2	 E x2		
			 F x2	 G x1		
 H x2	 I x2	 J x4	 K x4	 L x2	 M x1	
 N x2	 O x2	 P x2	 Q x2	 R x2	 S x2	 T x2
		 U x6	 V x2	 W x2	 X x2	 Y x2

1/. Montage de l'essieu

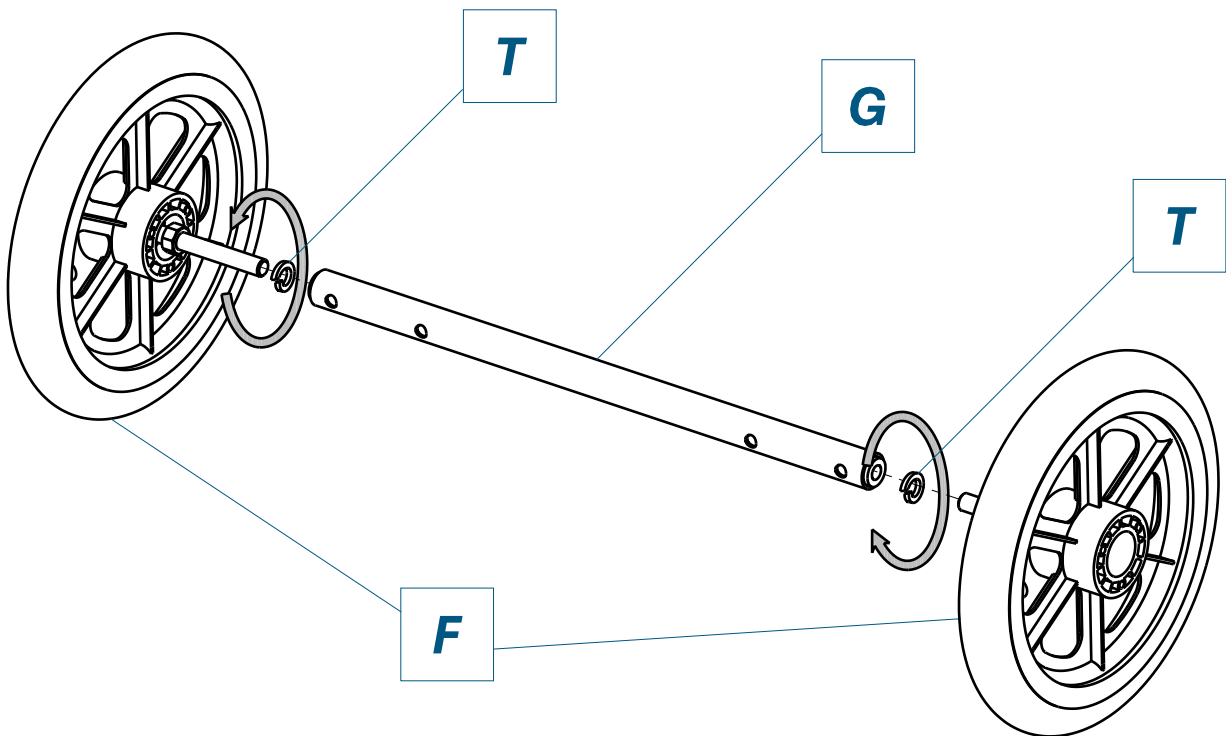

Bloquer fortement

4/. Montage des bras

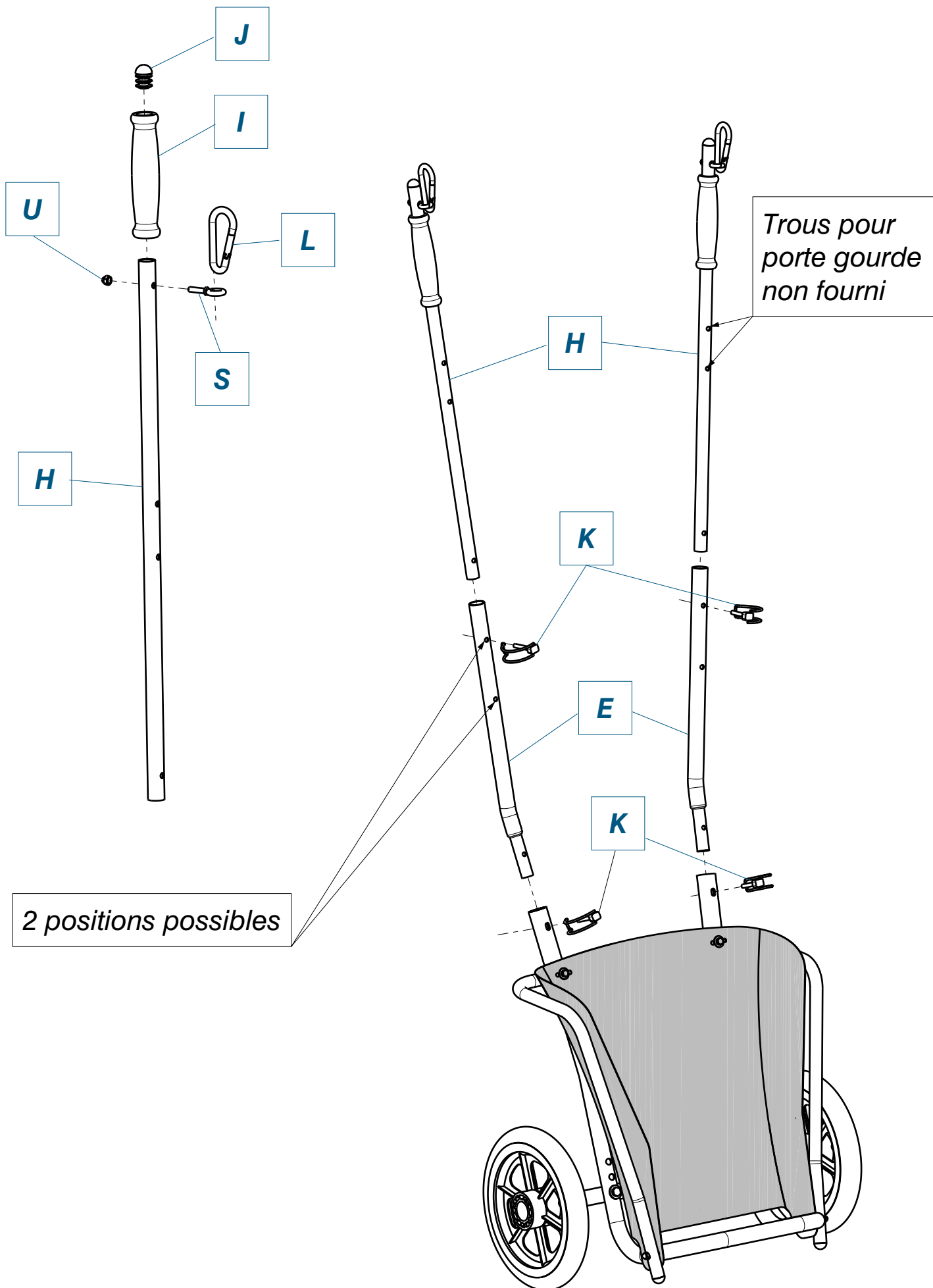

5/. Fixation de la ceinture

Détail A

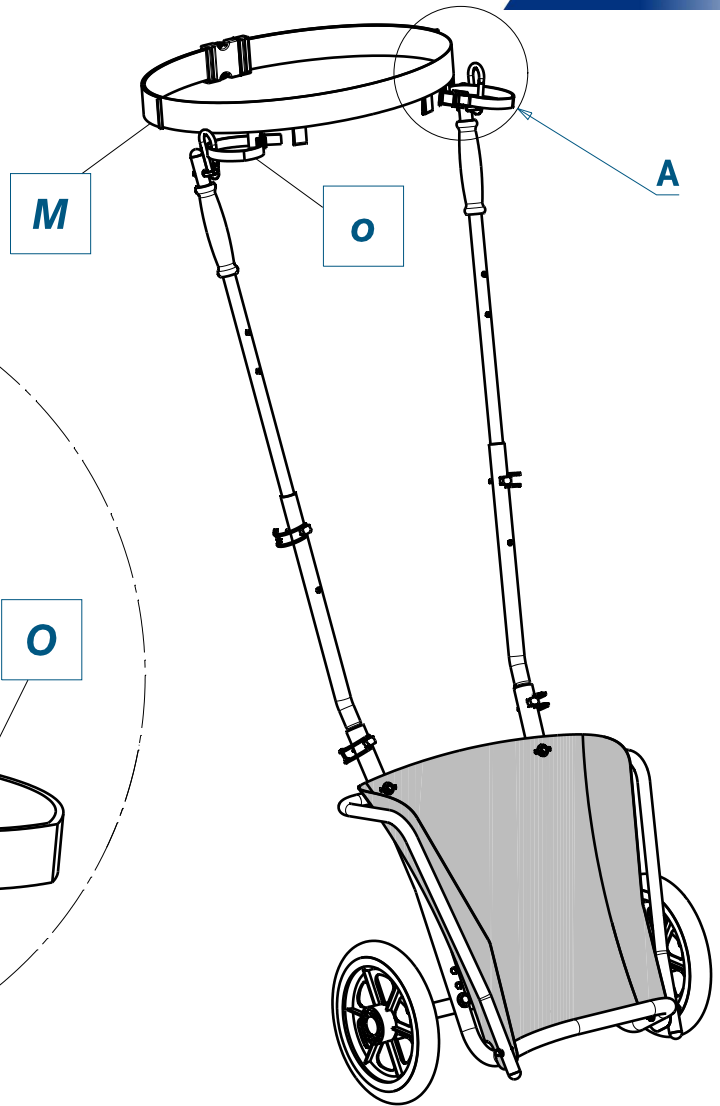
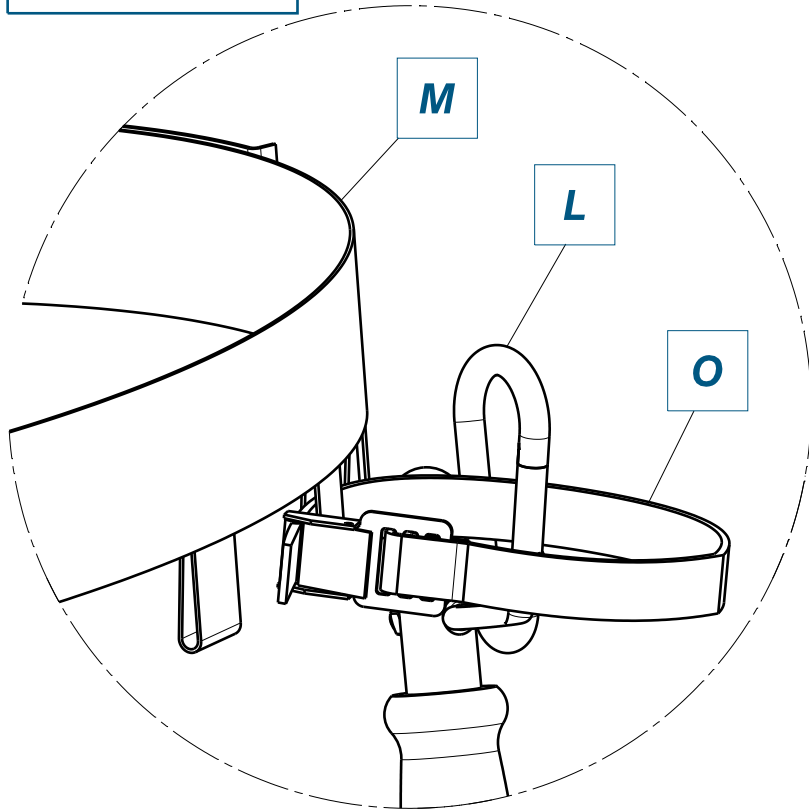

6/. Fixation des sandows

